

NAMUR Interface 3 Port Solenoid Valve

VFN200N Series



[Option]

The interface surface complies with NAMUR.

- Can be directly installed on the industrial valve actuator that complies with NAMUR.



How to Order

VFN212 N - 5 D Z - 02 F - -

NAMUR Interface

CE marking

1	100 VAC, 50/60 Hz
2	200 VAC, 50/60 Hz
3	110 to 120 VAC, 50/60 Hz
4	220 VAC, 50/60 Hz
5	24 VDC
6	12 VDC
7	240 VAC, 50/60 Hz

For other rated voltages, please contact SMC.

Voltage

Electrical entry

G	Grommet
E	Grommet terminal
T	Conduit terminal
D	DIN terminal
DO	DIN terminal (Without connector)
Y ^{Note)}	DIN terminal
Y0 ^{Note)}	DIN terminal (Without connector)

Note) Conforming to DIN 43650, Form B

Thread type

Nil	Rc (PT)
F	G (PF)
N	NPT

Solenoid

Nil	Single solenoid
D	Double solenoid

Manual override

Nil	Non-locking push type (Flush)
A	Non-locking push type (Extended)
B	Locking type (Tool required)

Light/Surge voltage suppressor

Nil	None
Z	With light/surge voltage suppressor
S ^{Note)}	With surge voltage suppressor

Note) Available for grommet type only.

Nil	—
Q	CE marked product

Specifications

Symbol

Single solenoid

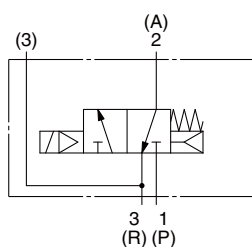

Double solenoid

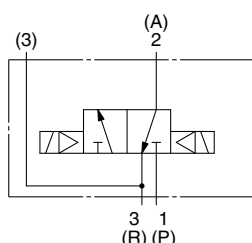

Valve specifications	Valve construction	Rubber seal		
	Fluid	Air		
	Valve type	Normally closed		
	Max. operating pressure	0.9 MPa (130 psi)		
	Min. operating pressure	0.15 MPa (22 psi)		
	Ambient and fluid temperature	-10 to +60°C ^{Note 1)}		
	Lubrication	Not required ^{Note 2)}		
	Pilot valve manual override	Non-locking push type (Flush/Extended)/Locking type (Tool required)		
	Enclosure	Dustproof		
	Port size	1/4		
	Cv factor (Effective area)	Refer to "Flow Rate Characteristics" table below.		
	Weight	Refer to "Weight" table below.		
	Other	Cylinder ports should be NAMUR hole pattern.		
	Electrical specifications	Coil rated voltage	12, 24 VDC, 100, 110 to 120, 200, 220, 240 VAC (50/60 Hz)	
Allowable voltage fluctuation		-15 to +10% of rated voltage		
Coil insulation type		Class B or equivalent		
Apparent power AC (Power consumption)		Inrush	5.0 VA/60 Hz, 5.6 VA/50 Hz	
		Holding	2.3 VA (1.5 W)/60 Hz, 3.4 VA (2.1 W) 9/50 Hz	
Power consumption DC		1.8 W		
Electrical entry	Grommet, Grommet terminal, Conduit terminal, DIN terminal			

Note 1) Use dry-air at low temperature.

Note 2) Use turbine oil No.1 (ISO VG32), if lubricated.

Flow Rate Characteristics

2-position		Flow rate characteristics					
		1→2 (P→A)			2→3 (A→R)		
		C	b	Cv	C	b	Cv
	Single solenoid	2.68	0.40	0.72	5.41	0.31	1.38
	Double solenoid	2.68	0.40	0.72	5.41	0.31	1.38

Weight

Model	Weight
VFN212N-5D-02F	240
VFN212N-5D-02F-D	380

(g)

IP

IW

1301

AW

IL1

IL2

IT

CP

IS

VFN

IN-
T

VFN200N Series

Dimensions

DIN terminal

VFN212N-□^D(Y)□□-02□-□

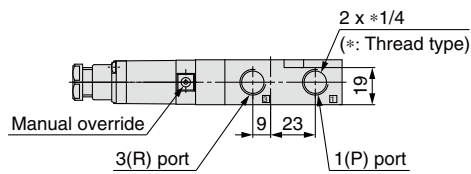
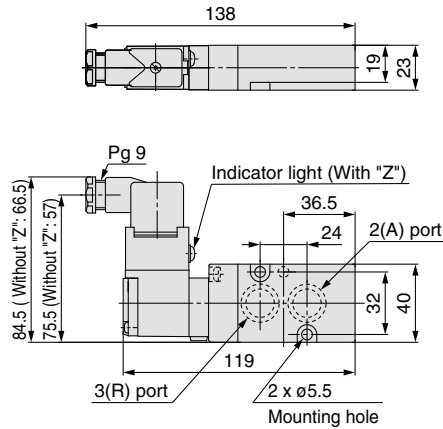
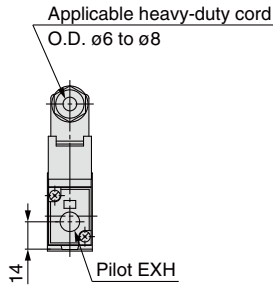

DIN terminal

VFN212N-□^D(Y)□□-02□-D-□

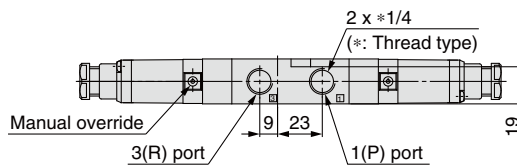
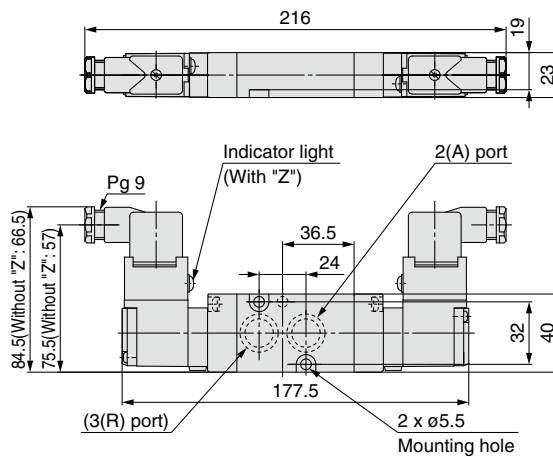
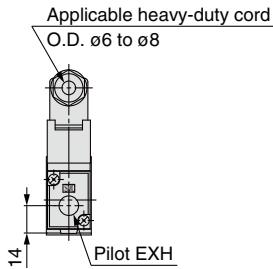

Grommet

VFN212N-□G□□-02□-□-□

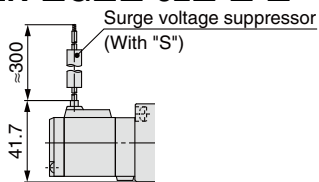

Grommet terminal

VFN212N-□E□□-02□-□-□

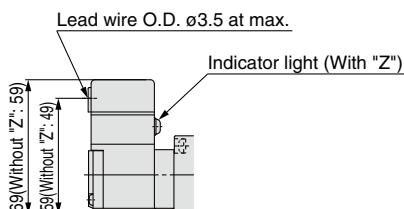

Conduit terminal

VFN212N-□T□□-02□-□-□

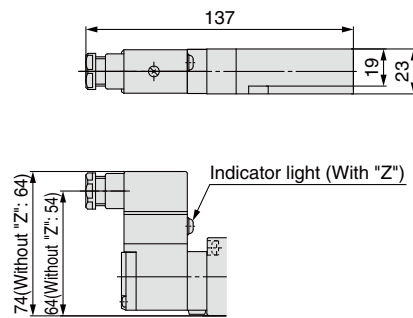

NAMUR Mounting Pattern

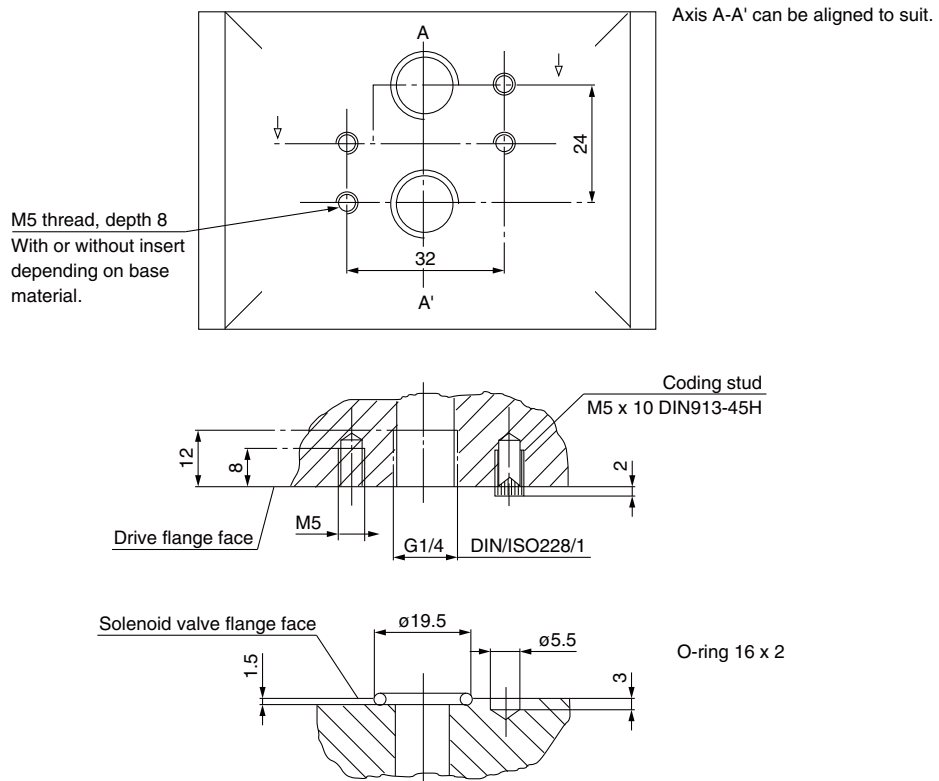

The solenoid valve can be attached with 2 mounting bolts.
The positioning of the coding stud hole is left up to the manufacturer and thus also determines the location of the coding stud.

IP
IW
1301
AW
IL1 <input type="checkbox"/>
IL2 <input type="checkbox"/>
IT
CP <input type="checkbox"/>
IS
VFN
IN-T <input type="checkbox"/>