

Regulator for General Applications

AK1000T Series

RoHS

For wide variety of applications from semiconductor to general.

Compact and lightweight

Weight

0.52 kg

Height

97.5 mm

Minimum dead leg construction

Multiple port available in various configurations

Selectable by • Compression • NPT female • Rc thread

High inlet pressure

Max. **24.1 MPa**

Flow capacity

<120 slpm

Leak rate

1.0×10^{-10} Pa·m³/s

Wetted parts material including diaphragm SUS316 (fluoropolymer seat)

Ni-Cr-Mo alloy internals available for corrosion resistance

Passivation internals

No oil

Cleaned for O₂ service

AP

SL

AZ

AK

BP



APTech

SMC

819

Best Pneumatics 10 Ver.6

Application Examples

Gas distribution facility

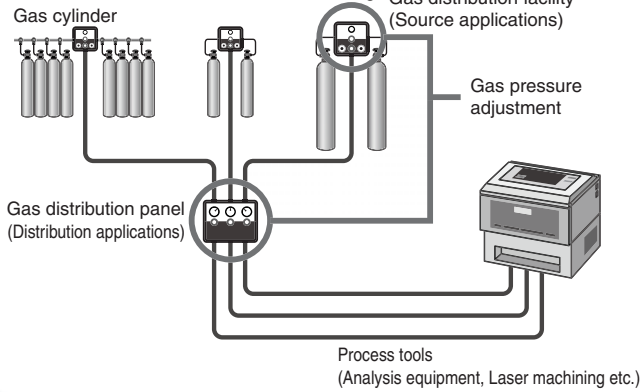

Cylinder cabinet

Supply pressure adjustment



Vacuum chamber

Purge gas adjustment



Leak Tester

Inspection helium gas adjustment



Laser machining

Assist gas adjustment



Analysis equipment

Carrier gas adjustment



Gas filling packing machine

Adjustment of inert gas to prevent spoilage



Related Products

Diaphragm Valve for General Applications AK Series

For details, refer to page 811.



- Rc, R and NPT connections are added to series.
- For wide variety of applications from semiconductor to general.
- Cleaned for O₂ service.
- Compact and lightweight by making the actuator shorter. (AK3542/4542)
- M5 actuation port. (AK3542/4542)
- Compact and lightweight by modifying the knob design. (AK3652/4652)
- The knob is a unique design that combines a scalloped round knob with a raised rectangular section to provide two choices of gripping. (AK3652/4652)

Series	Type	Body material	Connection	Connection size
AK	Air operated type	316 SS	Compression Rc, R, NPT	1/4", 3/8"
AK	Manually operated type			



AK Series Applicable Fluid

Precautions for selection

The proper regulator and valve selection can be significantly affected by parameters such as system design, flow duration, frequency of use, ambient conditions and outlet pressure. It is important to understand that one may follow this guide's recommendation, yet have a failure due to a parameter specific to the given application, as noted.

Applicable Fluid

Process Gas	Molecular Formula
Argon	Ar
Halocarbon 114	C ₂ Cl ₂ F ₄
Halocarbon 115	C ₂ ClF ₅
Halocarbon 116	C ₂ F ₆
Acetylene	C ₂ H ₂
Vinylidene Fluoride	C ₂ H ₂ F ₂
Halocarbon 134A	C ₂ H ₂ F ₄
Halocarbon 125	C ₂ HF ₅
Hexafluoropropylene	C ₃ F ₆
Halocarbon R218	C ₃ F ₈
Hexafluoropropane	C ₃ H ₂ F ₆
Propene	C ₃ H ₆
Propane	C ₃ H ₈
Halocarbon C318	C ₄ F ₈
Butene-1	C ₄ H ₈
n-Butane	C ₄ H ₁₀

Process Gas	Molecular Formula
Halocarbon 13B1	CBrF ₃
Halocarbon 12	CCl ₂ F ₂
Halocarbon 13	CClF ₃
Halocarbon 14	CF ₄
Halocarbon 32	CH ₂ F ₂
Methane	CH ₄
Halocarbon 23	CHF ₃
Carbon Dioxide	CO ₂
Hydrogen	H ₂
Helium	He
Krypton	Kr
Nitrogen	N ₂
Neon	Ne
Oxygen	O ₂
Xenon	Xe

AP

SL

AZ

AK

BP

· Following * symbols indicate toxic gas (allowable concentration 200 ppm or less). In Japan, according to METI, pipe thread (Rc, R, NPT etc) should not be used as connections of piping, fittings, and valves installed in gas systems.

Process Gas	Molecular Formula
Boron 11 Trifluoride*	11BF ₃
Arsine*	AsH ₃
Boron Trichloride*	BCl ₃
Boron Trifluoride*	BF ₃
Ethylene*	C ₂ H ₄
Dimethylsilane*	C ₂ SiH ₈
Perfluoro-butadiene*	C ₄ F ₆
Butadiene*	C ₄ H ₆
Octafluorocyclopentene*	C ₅ F ₈
Halocarbon 12B2*	CBr ₂ F ₂
Trimethylsilane*	(CH ₃) ₃ SiH
Methyl Bromide*	CH ₃ Br
Methyl Chloride*	CH ₃ Cl
Methyl Fluoride*	CH ₃ F
Methanol*	CH ₃ OH
Methylsilane*	CH ₃ SiH ₃
Halocarbon 21*	CHCl ₂ F
Chlorine*	Cl ₂
Chlorine Trifluoride*	ClF ₃
Carbon Monoxide*	CO
Carbonyl Fluoride*	COF ₂
Germane*	GeH ₄

Process Gas	Molecular Formula
Hydrogen Sulfide*	H ₂ S
Hydrogen Selenide*	H ₂ Se
Hydrogen Bromide*	HBr
Hydrogen Chloride*	HCl
Hydrogen Fluoride*	HF
Nitrogen Oxide*	N ₂ O
Nitrogen Trifluoride*	NF ₃
Ammonia*	NH ₃
Nitric Oxide*	NO
Phosphorous Pentafluoride*	PF ₅
Phosphine*	PH ₃
Sulfur Tetrafluoride*	SF ₄
Sulfur Hexafluoride*	SF ₆
Disilane*	Si ₂ H ₆
Silicon Tetrachloride*	SiCl ₄
Silicon Tetrafluoride*	SiF ₄
Dichlorosilane*	SiH ₂ Cl ₂
Silane*	SiH ₄
Trichlorosilane*	SiHCl ₃
Sulfur Dioxide*	SO ₂
Diethyltelluride*	Te(C ₂ H ₅) ₂
Tungsten Hexafluoride*	WF ₆

· This applicable fluid is a reference guide and does not apply to product guarantee.
· Please consult SMC for a specific recommendation beyond the scope of this document.

Caution

Since the product specified here is used under various operating conditions, its compatibility with fluid and specific equipment must be decided by the person who designs the equipment or decided its specifications based on necessary analysis and test results. The expected performance and safety assurance of the equipment will be the responsibility of the person who has determined its compatibility with the product regardless of any recommendation. Proper installation, operation and maintenance are also required to assure safe, trouble free performance.

Regulator for General Applications

Low to intermediate flow

AK1000T Series

- High inlet pressure type: Max. 3500 psig (24.1 MPa)
- Flow capacity < 120 slpm
- Ni-Cr-Mo alloy internals available for corrosion resistance



How to Order

Code	Ports	Ports	Connections			
			4	4BR	4T	6T
4PL	4 ports	Refer to the following porting configurations.	●	●	●	●
5PC	5 ports		●	—	●	●



Delivery pressure

Code	Delivery pressure
01	0.5 to 10 psig (0.0034 to 0.07 MPa)
02	1 to 30 psig (0.007 to 0.2 MPa)
06	2 to 60 psig (0.014 to 0.4 MPa)
10	2 to 100 psig (0.014 to 0.7 MPa)
15	5 to 150 psig (0.034 to 1.0 MPa)

Material

Code	Body	Poppet	Diaphragm
S	316 SS	316 SS	316 SS
SHP		Ni-Cr-Mo alloy	Ni-Cr-Mo alloy

Connections (Inlet ①, Outlet ②)

Code	Connections	Connections			
		4	4BR	4T	6T
4	NPT1/4	●	—	●	●
4BR	Rc1/4	—	●	—	—
4T	1/4 inch compression	●	—	●	●
6T	3/8 inch compression	●	—	●	●

Porting Configuration

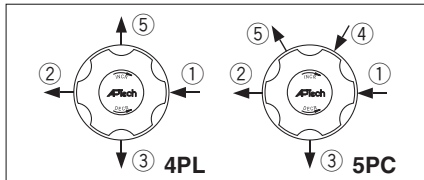

Sample Order Number

	Port ①	Port ②	Port ③	Port ④	Port ⑤	
AK1002TS	4PL	4	4	0	0	
	5PC	4T	4T	0	40	1 MPA

- ① IN ② OUT ③ Extra outlet port
④ Gauge port (Inlet) ⑤ Gauge port (Outlet)

Specifications

Operating Parameters	AK1001T	AK1002T	AK1006T	AK1010T	AK1015T
Delivery pressure	0.5 to 10 psig (0.0034 to 0.07 MPa)	1 to 30 psig (0.007 to 0.2 MPa)	2 to 60 psig (0.014 to 0.4 MPa)	2 to 100 psig (0.014 to 0.7 MPa)	5 to 150 psig (0.034 to 1.0 MPa)
Gas	Select compatible materials of construction for the gas				
Source pressure	Vacuum to 300 psig (2.1 MPa)		Vacuum to 3500 psig (24.1 MPa)		
Proof pressure	Inlet	1.5 times the maximum source pressure			
	Outlet	1.5 times the maximum delivery pressure			
Burst pressure	Inlet	3 times the maximum source pressure			
	Outlet	3 times the maximum delivery pressure			
Ambient and operating temperature	-40 to 71°C (No freezing)				
Leak rate	1 x 10 ⁻¹⁰ Pa·m ³ /s				
Connections	NPT female, Rc thread, Compression				
Supply pressure effect	1.2 pisp (0.008 MPa) rise in delivery pressure per 100 psig (0.7 MPa) source pressure drop				
Installation	Bottom mount (Option: Bracket mount/Order separately)				
Internal volume	0.3 in ³ (4.8 cm ³)				
Weight	0.52 kg ^{Note)}				

Note) Weight, including individual boxed weight, may vary depending on connections or options.

Flow Rate Characteristics

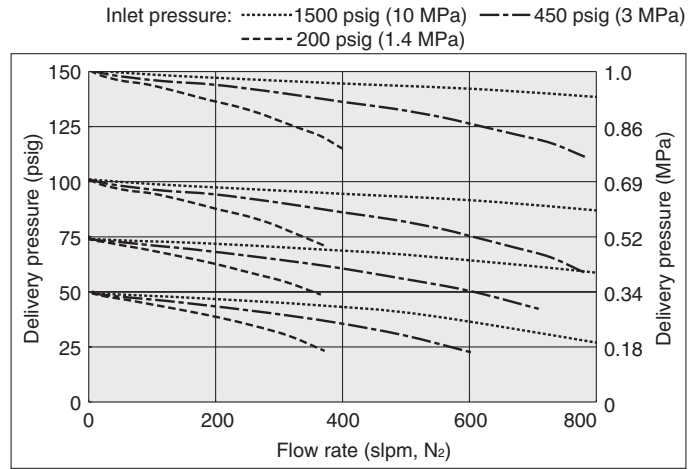
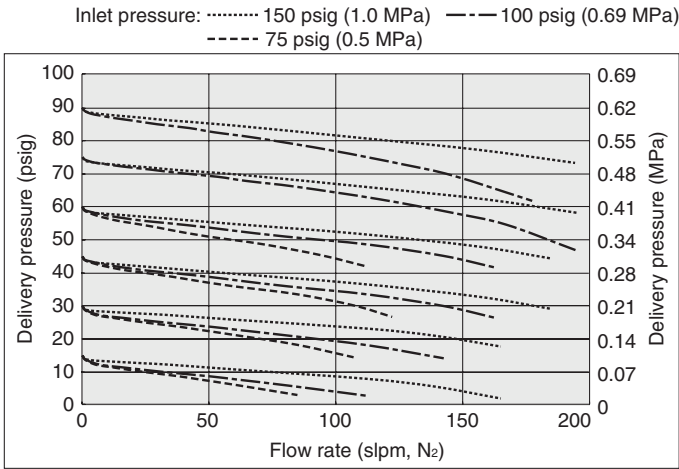

Dimensions

inch (mm)

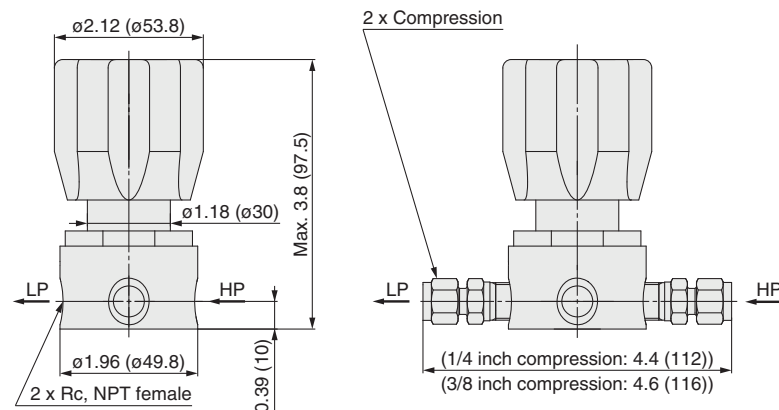
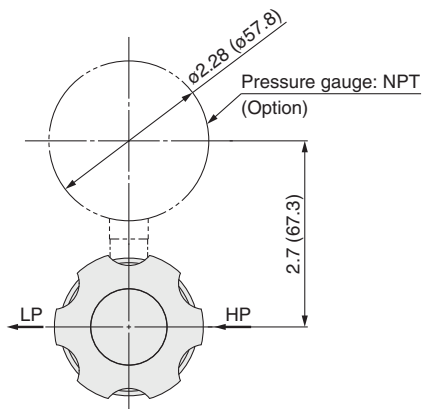

Connections: 4, 4BR

Connections: 4T, 6T

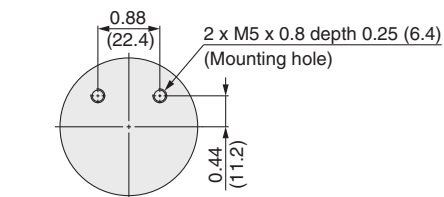

Bracket mount/Option

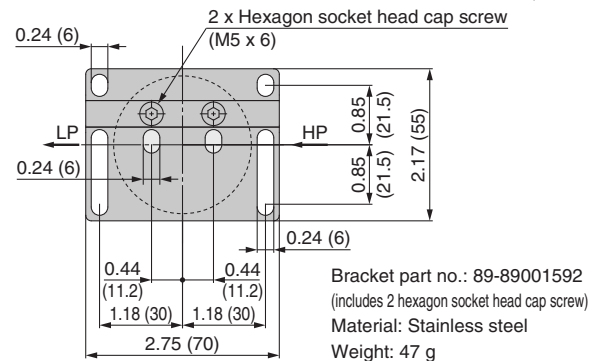
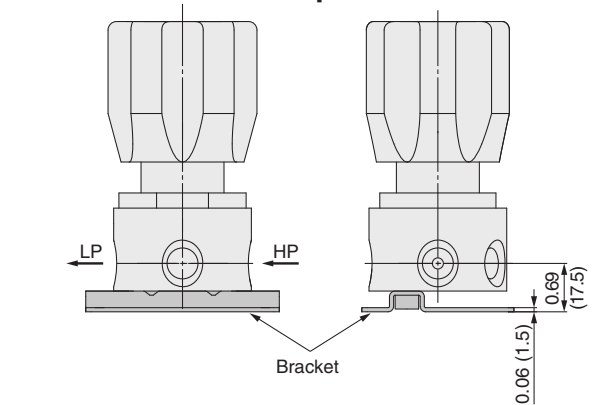

- AP
- SL
- AZ
- AK
- BP

AK1000T Series

For AK series (Installed before shipment/Order separately)



Stainless steel/Lower mount/NPT 1/4

Specifications

Installation	Lower mount	
Gas	Select compatible materials of construction for the gas	
Connections	NPT 1/4 inch	
Temperature range	-40 to 60°C (No freezing)	
Accuracy	25% to 75% of the scale: ±2%F.S. Other than above: ±3%F.S. (ASME B40.1 Grade B or better)	
Cleanliness	ASME B40.1 level IV	
No oil	No oil	
Material	Case	Stainless steel
	Window	Polycarbonate
	Socket	316 SS
	Bourdon tube	316 SS

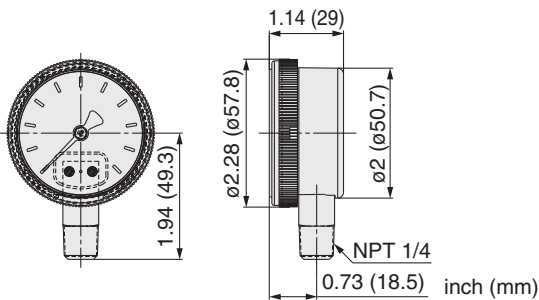

Model

Regulator Code ^{Note 2)}			Pressure range	Unit	Part number ^{Note 1)}
material	gauge port	unit			
S SHP	V15	(No code)	-30 in.Hg to 15 psig	Note 3) psig/bar	00-83000102
	V3		-30 in.Hg to 30 psig		00-83000184
	L		-30 in.Hg to 60 psig		00-83000181
	1		-30 in.Hg to 100 psig		00-83000182
	H		-30 in.Hg to 160 psig		00-83000196
	V2		-30 in.Hg to 200 psig		00-83000033
	2		0 to 200 psig		00-83000193
	4		0 to 400 psig		00-83000194
	10		0 to 1000 psig		00-83000187
	30		0 to 3000 psig		00-83000234
	40	0 to 4000 psig	00-83000183		
	V15	MPa	-0.1 to 0.1 MPa	MPa	00-83000287
	V3		-0.1 to 0.2 MPa		00-83000288
	L		-0.1 to 0.4 MPa		00-83000289
	1		-0.1 to 0.7 MPa		00-83000290
	H		-0.1 to 1.1 MPa		00-83000291
	V2		-0.1 to 1.4 MPa		00-83000292
	2		0 to 1.5 MPa		00-83000286
	4		0 to 3 MPa		00-83000285
	10		0 to 7 MPa		00-83000284
30	0 to 21 MPa		00-83000283		
40	0 to 28 MPa	00-83000282			

Note 1) Part number of pressure gauge itself. Gauge are shipped separately.

Note 2) When pressure gauge needs to be assembled with regulator when shipment, put this code as gauge port in How to Order.

Note 3) Under Japanese regulation, psig/bar unit gauge is not sold in Japan.

Warning

- ① Please make sure operating pressure does not exceed maximum pressure range of the pressure gauge
- ② For pressure gauge installation, follow the Mounting section in the Common Precautions 1 (P.633).
- ③ After installation, perform leak test.